



Stainless steel range - Hinges

Spring bracket hinges

Compact spring hinges 1.6 N.m



Opening spring force:

M(0°) : 1.6 N.m / M(90°) : 1.2 N.m / M(180°) : 0.84 N.m

Closing spring force:

M(0°) : 0.75 N.m / M(90°) : 1.2 N.m / M(180°) : 1.65 N.m

Spring: stainless steel



Part number	Material	Finish	A	B	C	D	Note	Weight (g)
NEW 71-1-3912	304 stainless steel	raw	85	55	2	5	opening spring / delivered flat	107
NEW 71-1-3914	304 stainless steel	raw	85	55	2	5	closing spring / delivered flat	107

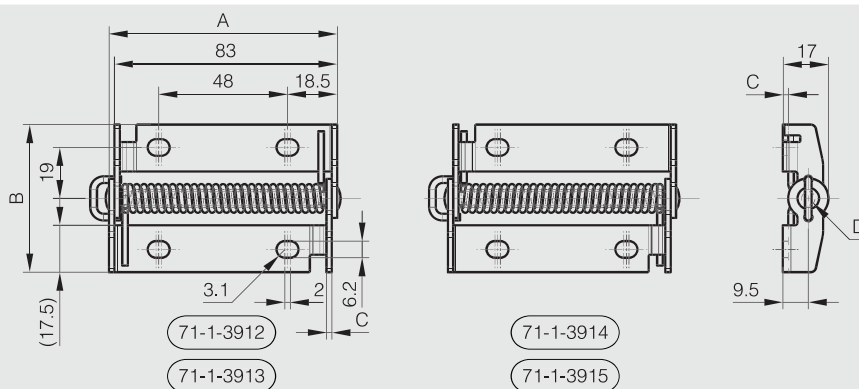

Compact spring hinges 2.2 N.m



Opening spring force:

M(0°) : 2.2 N.m / M(90°) : 1.6 N.m / M(180°) : 1.1 N.m

Closing spring force:

M(0°) : 1.0 N.m / M(90°) : 1.6 N.m / M(180°) : 2.2 N.m

Spring: stainless steel



Part number	Material	Finish	A	B	C	D	Note	Weight (g)
NEW 71-1-3913	304 stainless steel	raw	85	55	2	5	opening spring / delivered flat	107
NEW 71-1-3915	304 stainless steel	raw	85	55	2	5	closing spring / delivered flat	107

