

### Rolled knuckle continuous hinge - 57 mm width

Opening angle 270°. Other lengths and pin materials are available on request.

Specific drilling requirements are also available on request.

Hinge in raw galvanised steel is made of pregalvanised steel. Therefore any cut surface is ungalvanised.



Part number	Material	Finish	A	B	C	D	E	Pin material	Note	Weight (g)
40-1-4680	galvanised steel	raw	2160	57	1.5	4	15	brass	undrilled	2000
40-1-4682	galvanised steel	raw	2160	57	2	6	30	brass	undrilled	2970
42-1-4220	304 stainless steel	raw	2160	57	1.5	4	15	stainless steel	undrilled	2000

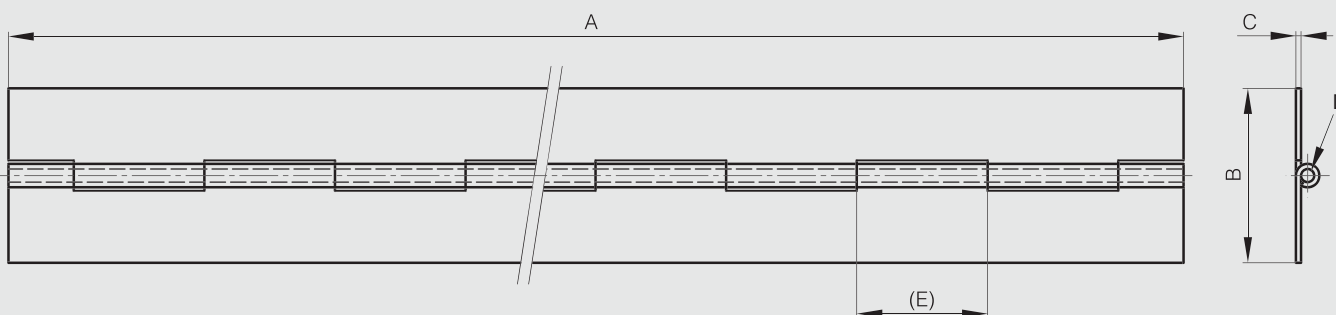

### Rolled knuckle continuous hinge - 60 mm width

Opening angle 270°. Other lengths and pin materials are available on request.

Specific drilling requirements are also available on request.



Part number	Material	Finish	A	B	C	D	E	F	G	S	Pin material	Note	Weight (g)
40-1-3541	steel	raw	1995	60	1.5	5	40				steel	undrilled	2006
40-1-3335	steel	raw	2000	60	1.5	8	40				steel	undrilled	2622
40-1-4371	steel	raw	2040	60	2	6	30				steel	undrilled	2800
41-1-3523	5754 alu	raw	1995	60	2	6	30				aluminium	undrilled	998
42-1-4086	304 stainless steel	raw	1020	60	2	6	30				stainless steel	undrilled	1400
42-1-3302	304 stainless steel	raw	2040	60	2	6	30				stainless steel	undrilled	2844
42-1-4201	304 stainless steel	raw	2040	60	2	6	30	35	60	4	stainless steel	drilled	2800
42-1-4085	316L stainless steel	raw	1020	60	2	6	30				stainless steel	undrilled	1470
42-1-4002	316L stainless steel	raw	2040	60	2	6	30				stainless steel	undrilled	2913

