



## Snap-in magnetic catches

### Snap-in magnets without counterplate

Snap-in magnets for sheet metal applications. Suitable for material thicknesses 1.6 mm or 2.6 mm.

E denotes material thickness.

Cut-out varies to suit metal thickness.

Flex-tab for easy removal.

POLYMER

Part number	Material	Finish	A	B	C	Force	Weight (g)
16-7-4209	POM	black	41	13	14.6	3kg	6

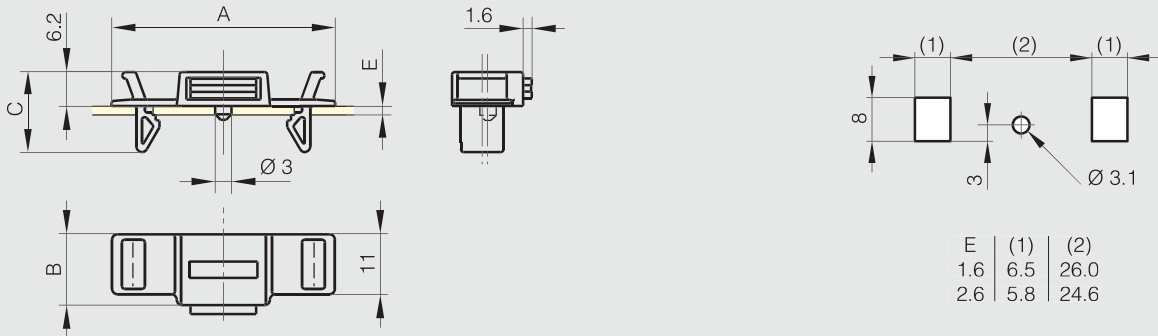

### Snap-in magnets

POLYMER RoHS

Part number	Material	Finish	A	B	C	D	E	Force	Note	Weight (g)
16-7-4013	polypropylene	white	25.5	12.3	10.4	23	11	1.5kg	for sheetmetal thickness 1.5mm	4
16-7-4015	polypropylene	white	39.5	10	11	35	8.2	4kg	for sheetmetal thickness 1.5mm	8
16-7-3674	polypropylene	black	54	12.5	14.5	51.5	10.8	15kg	for sheetmetal thickness 2.0mm	32

